

GREENMAX™ COMPACTOR ZEUS C100

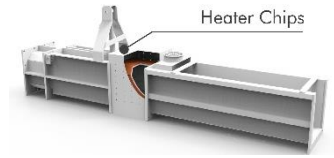

Compression Ratio:
50:1



> Surface melting technology melt the surface of compacted PE foam, the inside would not expand again.

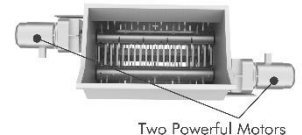

Two Powerful Motors



> SIEMENS control system guarantees easy and simple operation.



> Reputable & High quality components make the machine reliable and durable.



> CE approved and comply with UL/CSA standards

> Heavy crusher driven by two powerful motors is able to break PE foam, into 20-50 mm size small pieces.

> APPLICABLE MATERIAL:

POLYSTYRENE		POLYPROPYLENE	POLYETHYLENE
EPS	EPS CUPS / TRAYS	XPS	EPP

> DIMENSIONS

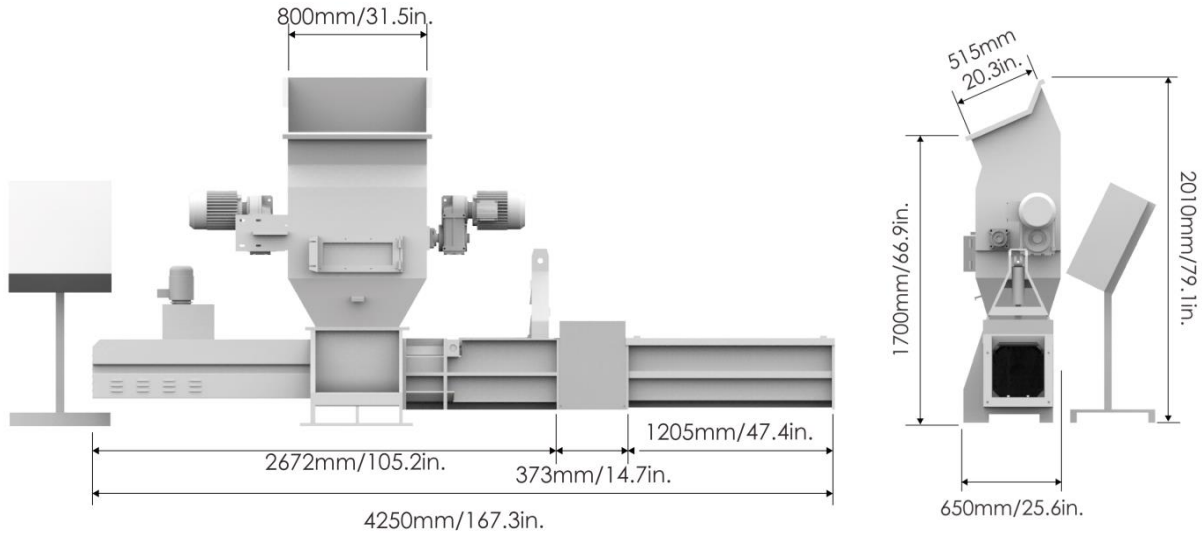

> TECHNICAL DATA

ITEM	Z-C100
Total Power Consumption	20.45 kw / 27.42 hp
Crusher Power Consumption	2*2.2 kw / 2*2.95 hp
Production Capacity	100 kg per hour / 220 lbs per hour
EPS Compression Ratio	50:1
Compressed EPS Density	200-400 kg/m ³ / 570-1140 lbs/cubic yard
EPS Block Dimensions	300*300 (w/h) mm / 11.8*11.8 (w/h) in.
Feed Hopper Door	800*515 (l/w) mm / 31.5*20.3 (l/w) in.
Dimensions	4250*650*2010 (l/w/h) mm / 167.3*25.6*79.1 (l/w/h) in
Shipping Dimensions	Main part: 3250*760*2220 (l/w/h) mm / 128.0*29.9*87.4 (l/w/h) in. Output chute: 1660*500*620 (l/w/h) mm / 65.4*19.7*24.4 (l/w/h) in.
Weight	1,600 kg / 3,520 lbs