

GREENMAX™ MELTER MARS C200

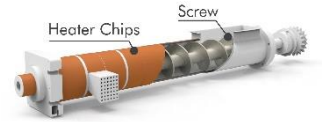

Compression Ratio:
90:1



> Screw melting technology enables continuous output at a ratio of 90:1. High-density ingot weights up to 25T per 40HQ container load.



> Equipped with reputable PHOENIX, SCHNEIDER, NSK components, GREENMAX ensures great safety, reliability and durability.



> Three stages of temperature control manipulate output color as white as possible.



> Easy operation. No Additional adjustment required during operation. Just start and stop.



> Easy 5S, Less foam scraps blow out and scatter on the ground during operation.



> GREENMAX machines are CE approved and comply with UL/CSA standards.

> APPLICABLE MATERIAL:

POLYSTYRENE		POLYETHYLENE		POLYPROPYLENE
EPS/ EPS DUST	EPS CUPS&TRAYS/ XPS	EPE	EPE ROLL/ EPE SHEET	EPP

> DIMENSIONS

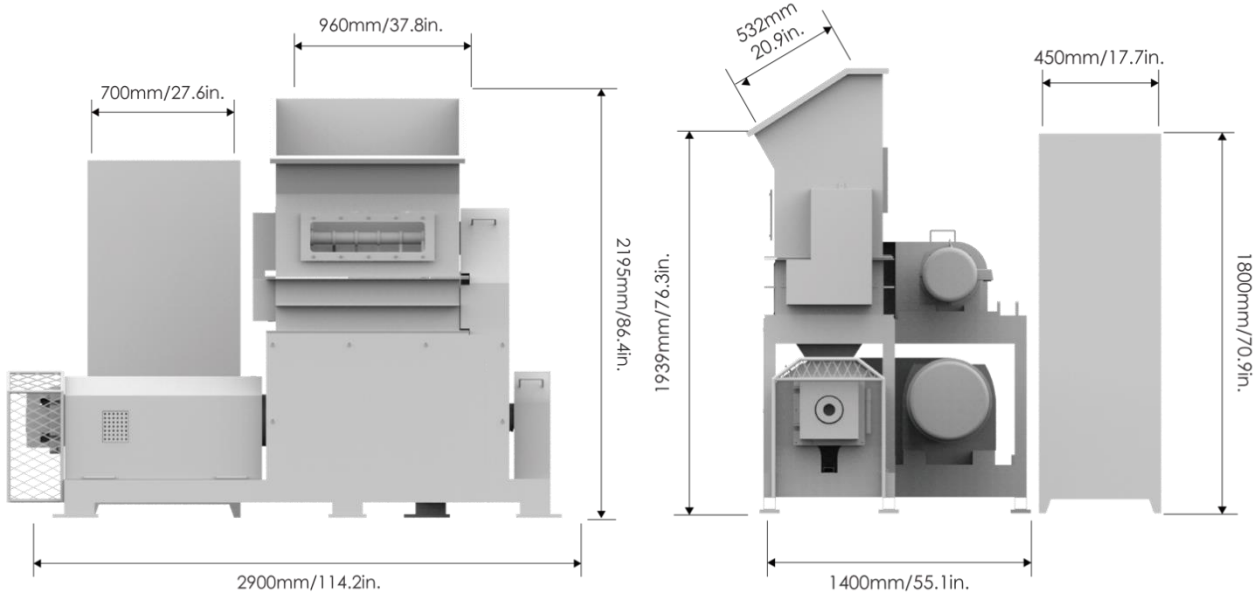

> TECHNICAL DATA

ITEM	M-C200
Motor Power	37.5 kw / 50 hp
Production Capacity	200 kg per hour / 440 lbs per hour
EPS Compression Ratio	90:1
Compressed EPS Density	600-800 kg/m ³ / 1320-1750 lbs/cubic yard
Feed Hopper Door	960*532 (l/w) mm / 37.8*20.9 (l/w) in.
Dimensions	2900*1400*2195 (l/w/h) mm / 114.2*55.1*86.4 (l/w/h) in.
Shipping Dimensions	3000*1500*2445 (l/w/h) mm / 118.1*59.1*96.3 (l/w/h) in.
Weight	2,500 kg / 5,500 lbs